

# Eclipse ThermAir

## Burners

Model TA0100

Version 2

Parameter		Specification	
		Packaged Blower Size	
<b>Maximum Input, BTU/hr (kW)<sup>1 2</sup></b> <i>(To maintain 15% air with the standard air orifice and standard combustion air blower.)</i>	<b>Chamber Pressure "w.c. (mbar)</b>	<b>3" w.c. (60 Hz)</b>	<b>6" w.c. (Nominal 50 &amp; 60 Hz)</b>
	-1.0 (-2,5)	1,141,000 (334)	1,030,000 (302)
	0.0 (0,0)	1,000,000 (293)	1,000,000 (293)
	1.0 (2,5)	835,000 (244)	900,000 (264)
<b>Minimum Input, BTU/hr (kW)</b>	Natural Gas	26,000 (7,6)	33,000 (9,7)
	Propane	28,000 (8,2)	33,000 (9,7)
	Butane	30,000 (8,8)	33,000 (9,7)
<b>Main Gas Inlet Pressure, "w.c. (mbar)<sup>3</sup></b> <i>Fuel pressure in gas inlet (Tap B)</i>		9.8 (24,1)	
<b>High Fire Flame Length, inches (mm)</b> <i>Measured from outlet end of combustor</i>	Natural Gas	47 (1194)	
	Propane, Butane	51 (1295)	
<b>Maximum Application Temperature, °F (°C)</b> <i>Note: For higher temperatures contact Eclipse.</i>	Alloy Tube	1500 (820)	
	SiC Tube	1900 (1040)	
<b>Flame Detection</b>		Flamerod or UV Scanner	
<b>Fuel<sup>4</sup></b> <i>For any other mixed gases, contact Eclipse.</i>		Natural gas, propane, or butane	
<b>Blower Motor Power</b>		3" w.c. @ 11500 scfh, 0.33 hp	6" w.c. @ 16500 scfh, 0.50 hp
<b>Weight, lbs (kg)<sup>5</sup></b>	With Blower	143 (65)	
	Without Blower	93 (42)	
<b>Approvals</b>			

- Maximum inputs are given for the standard packaged combustion air blower without an air filter.
- Blower motor service factors greater than 1.0 may be required when firing into negative chamber pressure applications. For specific application questions, contact Eclipse.
- For proper performance, this pressure must be kept constant across the burner operating range.
- See Design Guide 114 for more information about typical fuel composition and properties.
- All weights are approximate.
  - All information based on laboratory testing in neutral (0.0" w.c.) chamber with standard combustion design. Different chamber conditions and/or combustor design will affect the data.
  - All inputs are based upon gross calorific values and standard conditions: 1 atmosphere, 70°F (21°C).
  - Eclipse reserves the right to change the construction and/or configuration of our products at any time without being obliged to adjust earlier supplies accordingly.

## Performance Graphs

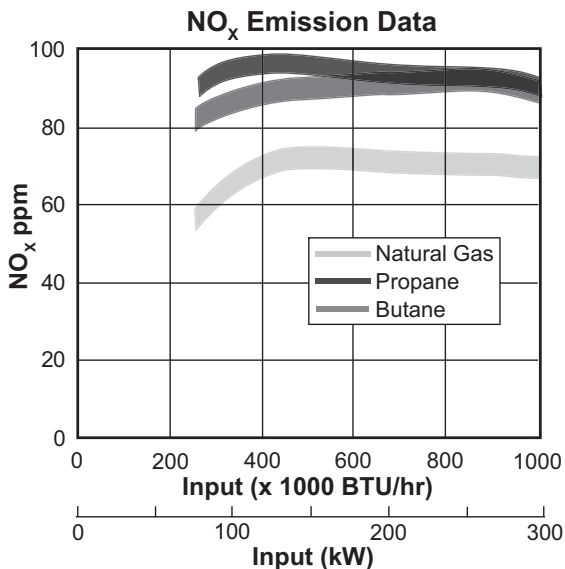
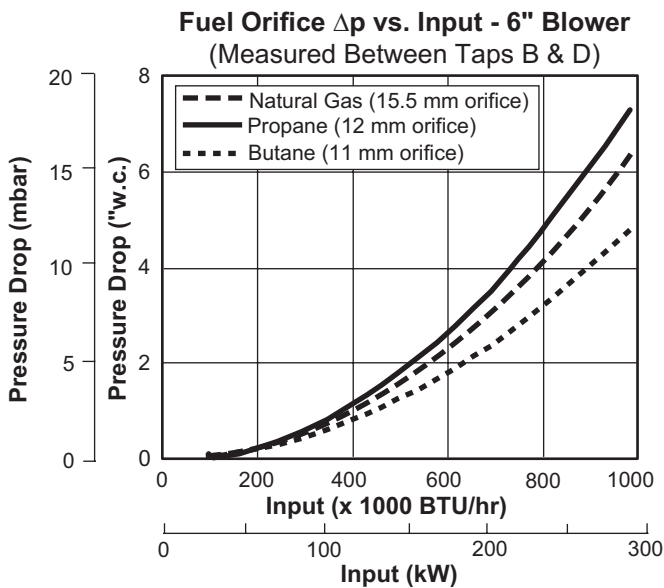
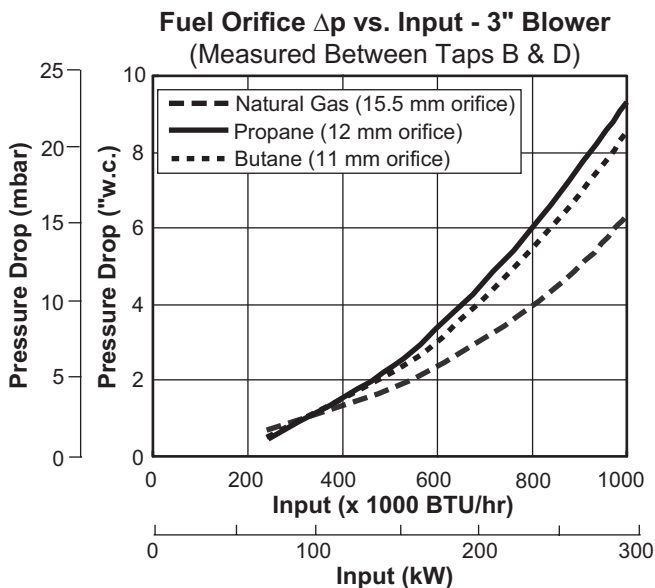
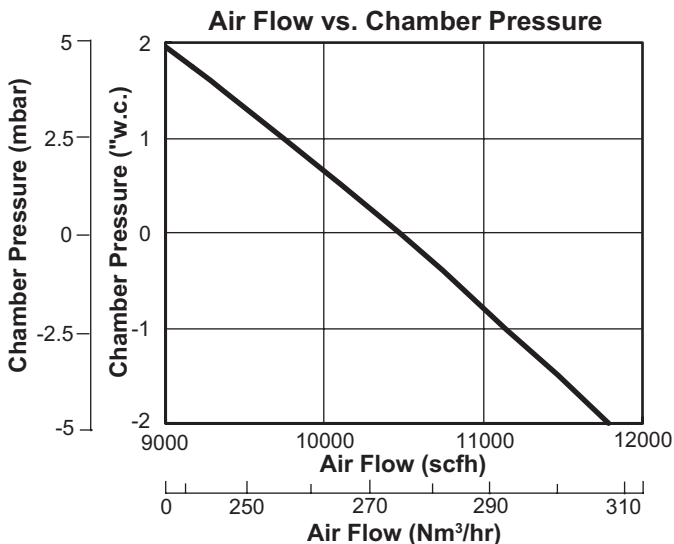
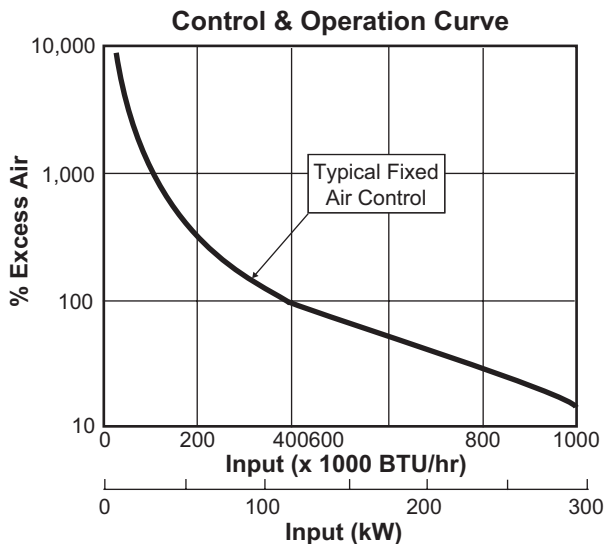

#### NO<sub>x</sub> emission data is given for:

- Ambient combustion air ~70°F (20°C)
- Minimal process air velocity
- ppm volume dry at 3% O<sub>2</sub>
- Neutral chamber pressure

#### Emissions are influenced by:

- Chamber conditions
- Fuel type
- Firing rate
- Ratio regulator adjustment
- Combustion air temperature

CO emission is largely influenced by chamber conditions. Contact your local Eclipse representative for an estimate of CO emission on your application.

## Dimensions mm (inches)

Blower	EE	FF	GG	HH
60 Hz (6" wc)	587 (23.1)	494 (19.4)	423 (16.7)	403 (15.9)
50 Hz (6" wc)	639 (25.2)	546 (21.5)	479 (18.9)	453 (17.8)

Combustor Type	JJ	KK
Straight Alloy Tube	137.2 (5.4)	141 (5.55)
Straight Silicon Tube	136 (5.35)	147.8 (5.82)

### Packaged Blower

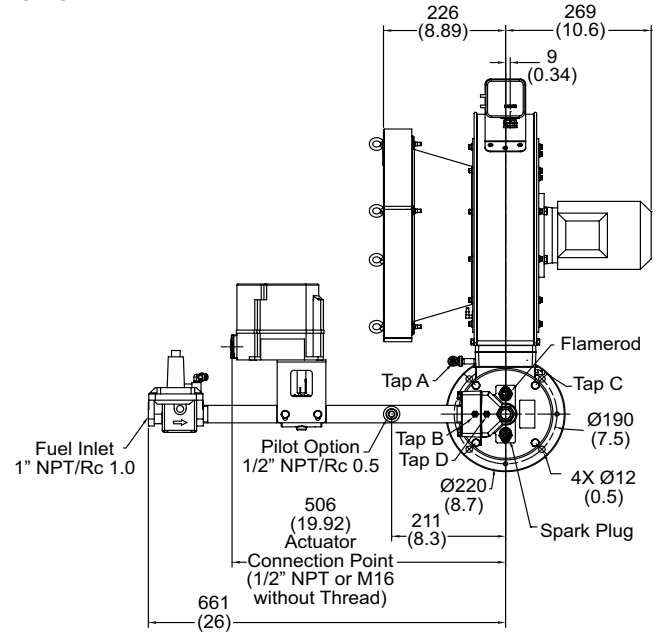
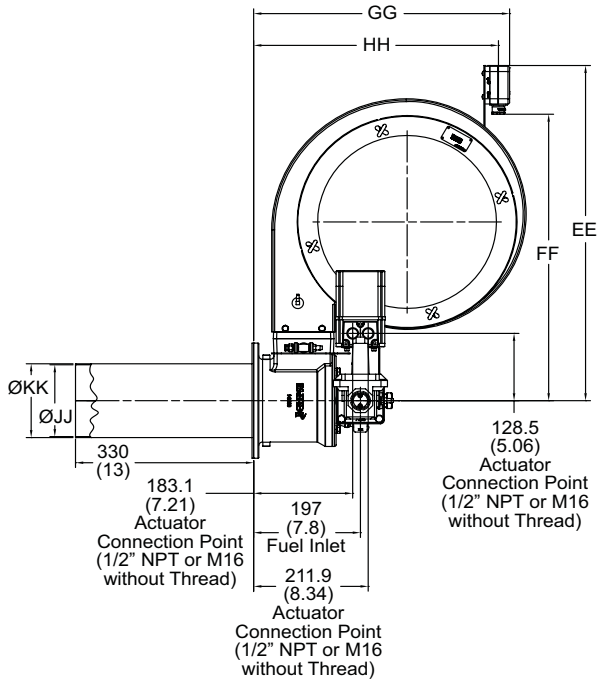

### Remote Blower

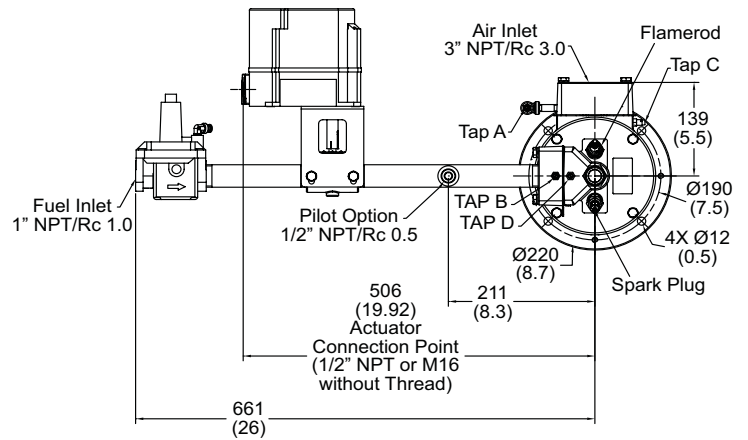
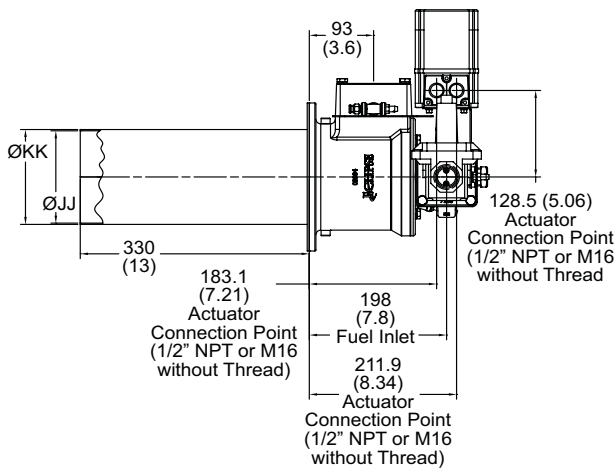

# Piping

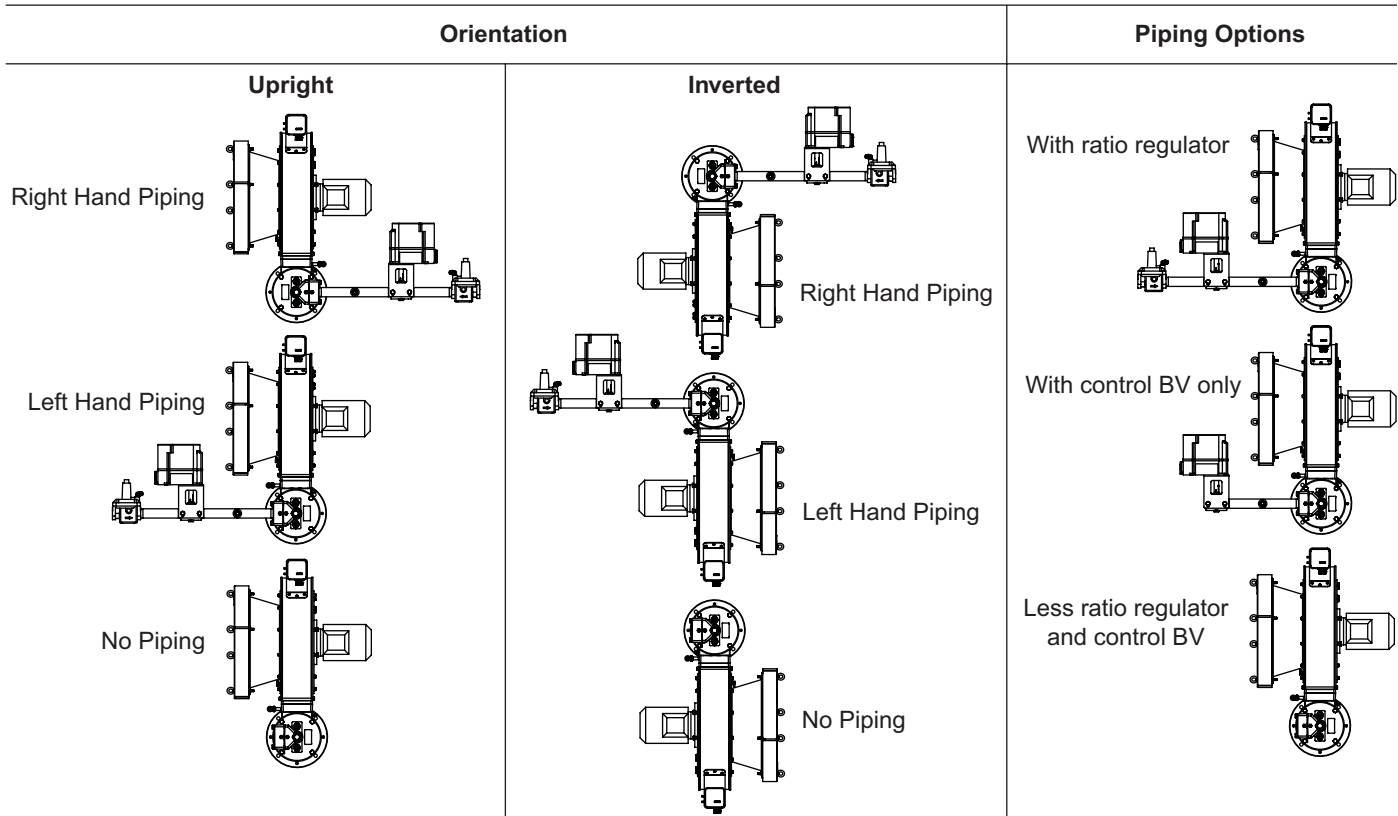

Ratio regulator not available for  
3" w.c. packaged version



**Offered By:**

Power Equipment Company  
2011 Williamsburg Road  
Richmond, Virginia 23231  
Phone (804) 236-3800  
Fax (804) 236-3882

---

[www.peconet.com](http://www.peconet.com)